

# SEAL SPEC F02

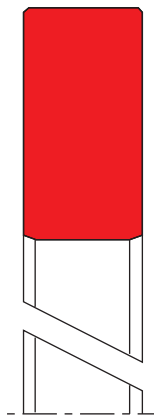

## description

for rod or piston application, split and non split design available. not only used as guiding, also as plain washer or spacer.

## category of profile

machined only product.

## operating parameter & material

material	temperature	surface speed max	specific load max
POM	-50 °C ... +100 °C	4,0 m/s	25 N/mm <sup>2</sup>
PA	-40 °C ... +100 °C	4,0 m/s	25 N/mm <sup>2</sup>
PTFE glass	-200 °C ... +200 °C	4,0 m/s	3 N/mm <sup>2</sup>
PTFE bronze	-200 °C ... +200 °C	5,0 m/s	4,5 N/mm <sup>2</sup>
TEX	-40 °C ... +130 °C	1,0 m/s	90 N/mm <sup>2</sup>

POM up to ø260 mm, PA above ø260 mm

the stated operation conditions represent general indications. it is recommended not to use all maximum values simultaneously. surface speed limits apply only to the presence of adequate lubrication film.

## tolerance recommendation

seal housing tolerance	
Ød	f8
ØD	H9

## seal & housing recommendations

please note that we are able to produce those profiles to your specific need or any non standard housing. for detail measurements, please see seal-mart catalog...

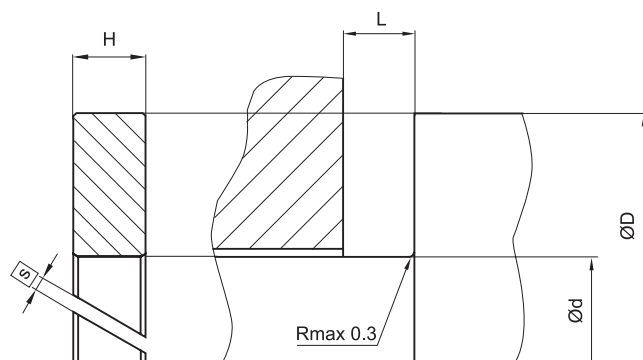

### variations:

- cutting gap width s=...mm
- endless

