

SEAL SPEC F06

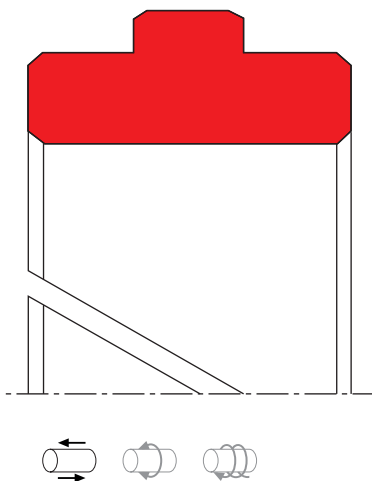

description

with integrated collar on inside diameter, for piston application. split and non split design available.

category of profile

machined only product.

application

for the guidance of pistons in hydraulic and pneumatic cylinders. In the case of pneumatic systems the application is, however, restricted to lubricated air.

operating parameter & material

material	temperature	surface speed max	specific load max
POM	-50 °C ... +100 °C	4,0 m/s	25 N/mm ²
PA	-40 °C ... +100 °C	4,0 m/s	25 N/mm ²
PTFE glass	-200 °C ... +200 °C	4,0 m/s	3 N/mm ²
PTFE bronze	-200 °C ... +200 °C	5,0 m/s	4,5 N/mm ²
TEX	-40 °C ... +130 °C	1,0 m/s	90 N/mm ²

POM up to ø260 mm, PA above ø260 mm

the stated operation conditions represent general indications. it is recommended not to use all maximum values simultaneously. surface speed limits apply only to the presence of adequate lubrication film.

tolerance recommendation

seal housing tolerance	
Ød	f8
Ød1	H8
ØD	H10

seal & housing recommendations

please note that we are able to produce those profiles to your specific need or any non standard housing. for detail measurements, please see seal-mart catalog...

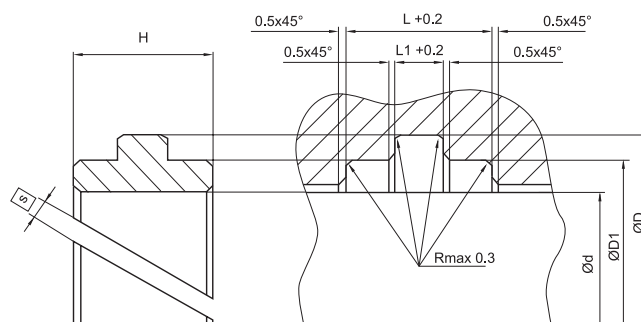

variations:
- cutting gap width s=...mm
- endless

