

SEAL SPEC

K04-P

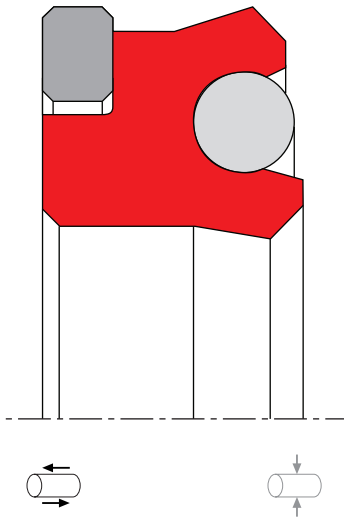

description

asymmetric piston seal for standard applications as K03-P, but due to design with active back-up ring suitable for larger extrusion gaps or higher pressure. K04-P for standard housing design.

- + asymmetric single acting piston compact seal, with the dynamic sealing lip being shorter than the static one. In addition, an o-ring inserted into the groove increases the preload.
- + interference fit on the inside diameter.
- + various materials are available for different purposes.
- + snaps into simple grooves (see notes on installation).
- + best sealing effect across a wide temperature range.
- + the active back up ring on the trailing side of the seal reduces extrusion wear and allows larger gap dimensions respectively higher system pressure.
- + for pressures up to 700 bar as a seal between pressurised spaces.
- + good sealing in low pressure ranges.
- + excellent static and dynamic sealing.
- + suitable for short travel.
- + no reverse leakage (i.e. minor relative motion of the sealing edges when the direction is changed).
- + shorter seal lengths require design K04-PD.

category of profile

machined product only

single acting

the K04-P seal is designed for use as a piston seal - either single or double acting where two seals are used 'back to back'

area of application; hydraulics

- reciprocating pistons in hydraulic cylinders.
- as piston seals for switching functions (e.g. clutch operation).
- as piston seals for clamping functions.

note

- this seal has the correct functioning dimensions only when mounted. in unmounted condition, the seal may appear too small.
- the ratio between nominal width and sealing height c_s/H should not drop below a value of 1/1.25 (essentially according to ISO 5597 housings for piston and rod seals).
- high degree of friction.
- high break-away moment.
- the recovery volume is smaller than with simple lip seals.
- cross-section limited to 20 mm.
- design K04-PD with triangular backupring can lead to installation difficulties.

function

K04-P and K04-PD profiles are compact lip seals designed to seal pressurised space against the atmosphere or - in case of back to back arrangement with intermediate guide ring to seal between two pressurised spaces, mainly for reciprocating movements. the design is based on application in standard hydraulic systems with conventional hydraulic oils. the operating parameters are as defined in the sealing data sheet and material data. requirements deviating from these parameters can be met to a certain degree by changing the geometry in the software program.

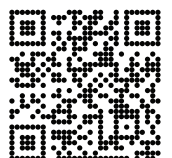

operating parameter & material

sealing element	material energizer	back-up ring	temperature	max surface speed	max pressure ¹	hydrolysis	dry running	max surface speed
PU	NBR	POM/PA ²	-30 °C ... +100 °C	0,5 m/s	700 bar (70 MPa)	-	+	+
HPU	NBR	POM/PA ²	-20 °C ... +100 °C	0,5 m/s	700 bar (70 MPa)	-	+	+
LTPU	NBR	POM/PA ²	-30 °C ... +100 °C	0,5 m/s	700 bar (70 MPa)	-	+	+
SPU	NBR	POM/PA ²	-20 °C ... +100 °C	0,7 m/s	700 bar (70 MPa)	-	+	+
GPU	NBR	POM/PA ²	-30 °C ... +100 °C	0,5 m/s	700 bar (70 MPa)	-	+	+

¹ pressure ratings are dependent on the size of the extrusion gap.

++ particularly suitable

+ suitable

o conditional suitable

- not suitable

² POM up to ø260 mm, PA above ø260 mm

the stated operation conditions represent general indications. it is recommended not to use all maximum values simultaneously. surface speed limits apply only to the presence of adequate lubrication film.

for detailed information regarding chemical resistance please refer to our „list of resistance“. for increased chemical and thermal resistance resp. for higher gliding speeds PTFE-materials should be used (e.g. profile K09-F or a different sealing system)

note on special material:

materials such as Viton, Silicone, EPDM, H-NBR, etc. can also be used for the preload element, but they are only useful in specific cases (temperature or chemical influences). the temperature limits are also determined by the supporting element; using special material can expand the temperature range.

gap dimension

operating pressure	cs = (ØD - Ød)/2 mm					
	4	5	7,5	10	12,5	15
200 bar (20 MPa)	0,62	0,75	0,90	1,15	1,35	1,60
400 bar (40 MPa)	0,27	0,36	0,45	0,55	0,65	0,75
600 bar (60 MPa)	0,27	0,19	0,21	0,23	0,25	0,26
700 bar (70 MPa)	0,05	0,07	0,10	0,13	0,15	0,17

the above data are maximum value and can't be used at the same time. e.g. the maximum operating speed depend on material type, pressure, temperature and gap value. temperature range also dependent on medium.

the table applies to an operating temperature of 70 °C. use larger cross sections to increase maximum allowed gap dimension. if the permissible extrusion gap cannot be achieved, K04-P is to be used.

surface quality

surface roughness	Rtmax (µm)	Ra (µm)
sliding surface	≤2,5	≤0,1-0,5
bottom of groove	≤6,3	≤1,6
groove face	≤15	≤3

tolerance recommendation

seal housing tolerance	
Ød	h10
ØD	H9

mode of installation

for inside diameters of 40 mm and more, the seal can generally be slipped over the piston and snapped into closed grooves. due to occurring deformation force at installation, assembly aid tools are to be used for large cross-sections. the material deformation should not exceed the value of 20%, otherwise the permanent deformation would be too large.

insertion chamfer

in order to avoid damage to the piston seal during installation, the piston and the housing is to be chamfered and rounded as shown in the "recommended mounting space" drawing. the size of chamfer depends on the seal type and profile width.

cs (mm)	c (mm)	
	α = 15° ... 20°	α = 20° ... 30°
4	3,5	2
5	4	2,5
6	4,5	3
7,5	5	4
10	6	5
12,5	8,5	6,5
15	10	7,5
20	13	10

instead of a chamfer, the piston can also be designed with a radius. recommended size of the radius is equal to size of chamfer (R=c).

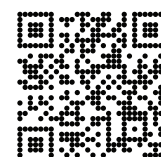

SEAL SPEC K04-P

recommended mounting space

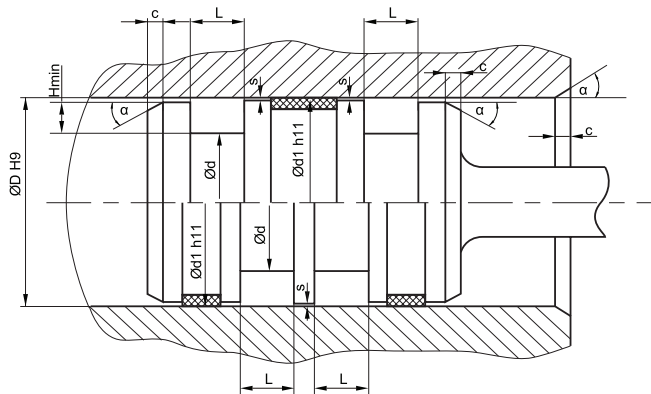

plastic guiderings (wearbands) have to feature a adequate cutting gap (recommendation: 2-5% of D). if metallic guides are used, spiral grooves shall be provided. smaller values for Hmin will ease the installation (reduced elongation and mounting force) but the height of the retaining collar has to be sufficient to assure a stable fit in the housing (larger than $cs/2$, smaller retaining collars will increase the danger of eversion of the profile in case of occuring drag pressure). in order to avoid drag pressure built up in case of back-to-back arrangement, the distance between the seals should be as small as possible.

fitted

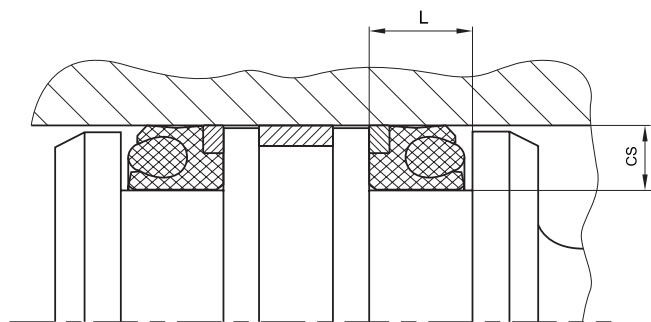

seal & housing recommendations

please note that we are able to produce those profiles to your specific need or any non standard housing. for detail measurements, please see seal-mart catalog...

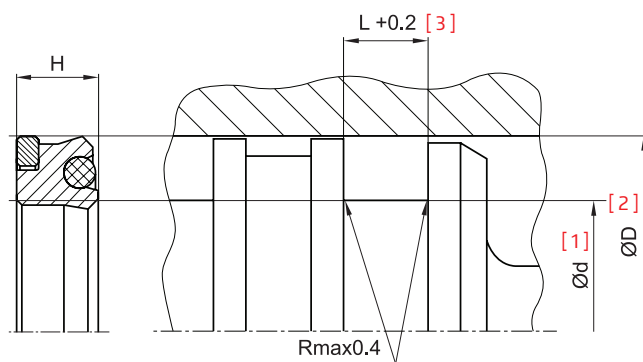

Ød [mm] [1]	ØD [mm] [2]	L [mm] [3]	$cs = (\text{ØD} - \text{Ød})/2$ [mm]
ØD - 8	5 ~ 24,9	6	4
ØD - 10	25 ~ 49,9	7	5
ØD - 12	50 ~ 74,9	8	6
ØD - 16	75 ~ 149,9	10	7,5
ØD - 20	150 ~ 299,9	12	10
ØD - 24	300 ~ 500	18	12,5
ØD - 30	500 ~ 750	20	15
ØD - 40	> 750	26	20

the ratio between nominal width and seal height cs/H should not drop below $1/125$. therefore we recommend the following housing heights.

