

SEAL SPEC

S03-P

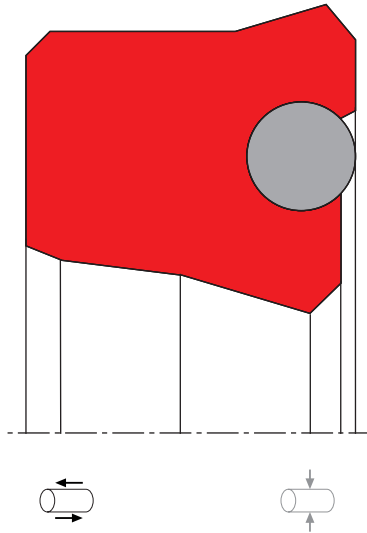

description

o-ring activated, asymmetrical rod seal. interference fit on outside diameter maintains stable fit in the housing. design provides ultimate sealing effect. especially suitable for short stroke applications (e.g. spindle seals, coupling actuators...).

- + asymmetric single-acting rod lip seals, with the dynamic sealing lip being shorter than the static one. in addition, an o-ring inserted into the groove increases the preload.
- + interference fit on the inside diameter.
- + various materials are available for different purposes.
- + snaps into simple grooves (see notes on installation).
- + best sealing effect across a wide temperature range.
- + sealing effect enhanced by high recovery rate.
- + for pressures up to 400 bar as a seal between pressurised spaces.
- + good sealing in all pressure ranges.
- + excellent static and dynamic sealing.
- + suitable for short travel.
- + no reverse leakage (i.e. minor relative motion of the sealing edges when the direction is changed).
- + recommended when holding or positioning underpressure.

category of profile

machined product only

single acting

the S03-P seal is designed for use as a rod seal.

area of application; hydraulics

- reciprocating rods on hydraulic cylinders, push rods, fittings.
- as rod seals for switching functions (e.g. clutch operation).
- as rod seals for clamping functions
- when an appropriate preload element is used, also suitable for low temperatures (down to -50°C).

note

- this seal has the correct functioning dimension only when mounted. when slipping the seal over the piston rod, it may appear too large.
- the ratio between nominal width and sealing height cs/H should not drop below a value of $1/1.25$ (essentially according to ISO 5597 housings for piston and rod seals).
- high degree of friction.
- high break-away moment.
- the recovery volume is smaller than with simple lip seals.
- cross-section limited to 20 mm.

function

S03-P profiles are lip seals designed to seal pressurised space against the atmosphere; mainly for reciprocating movements. the design is based on application in standard hydraulic systems with conventional hydraulic oils. the operating parameters are as defined in the sealing data sheet and material data. requirements deviating from these parameters can be met to a certain degree by changing the geometry in the software program.

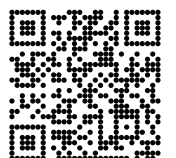

operating parameter & material

sealing element	material energizer	back-up ring	temperature	max surface speed	max pressure ¹	hydrolysis	dry running	wear resistance
PU	NBR (70 shore A)	-	-30 °C ... +100 °C	0,5 m/s	400 bar (40 MPa)	-	+	++
HPU	NBR (70 shore A)	-	-20 °C ... +100 °C	0,5 m/s	400 bar (40 MPa)	-	+	++
SPU	NBR (70 shore A)	-	-50 °C ... +100 °C	0,5 m/s	400 bar (40 MPa)	-	+	++
LTPU	NBR (70 shore A)	-	-20 °C ... +100 °C	0,7 m/s	400 bar (40 MPa)	-	++	++
GPU	NBR (70 shore A)	-	-30 °C ... +100 °C	0,5 m/s	400 bar (40 MPa)	-	+	++

¹ pressure ratings are dependent on the size of the extrusion gap.

++ particularly suitable

+ suitable

o conditional suitable

- not suitable

the stated operation conditions represent general indications. it is recommended not to use all maximum values simultaneously. surface speed limits apply only to the presence of adequate lubrication film.

for detailed information regarding chemical resistance please refer to our „list of resistance“. for increased chemical and thermal resistance rubber materials are to be preferred, attention should be paid to restrictions for pressure range and wear resistance. for higher gliding speeds another system should be used (e.g. PTFE materials).

note on special material:

other materials such as Viton, Silicone, EPDM, H-NBR, etc., can be used for the preload element, but they are only useful in specific cases (temperature or chemical influences).

gap dimension

operating pressure	cs = (ØD - Ød)/2 mm					
	4	5	7,5	10	12,5	15
	safe extrusion gap (mm)					
100 bar (10 MPa)	0,18	0,22	0,32	0,38	0,45	0,53
200 bar (20 MPa)	0,12	0,16	0,25	0,33	0,40	0,45
300 bar (30 MPa)	0,07	0,13	0,21	0,28	0,36	0,42
400 bar (40 MPa)	0,05	0,10	0,19	0,26	0,33	0,39

the above data are maximum value and can't be used at the same time. e.g. the maximum operating speed depend on material type, pressure, temperature and gap value. temperature range also dependent on medium.

use larger cross sections to increase maximum allowed gap dimension. if the permissible extrusion gap cannot be achieved, S04-P is to be used.

surface quality

surface roughness	Rtmax (µm)	Ra (µm)
sliding surface	≤2,5	≤0,1-0,5
bottom of groove	≤6,3	≤1,6
groove face	≤15	≤3

tolerance recommendation

seal housing tolerance	
Ød	f8
ØD	H10

mode of installation

Ød	type of installation
≤ 6·cs	open mounting space required
> 6·cs ≤ 10·cs	snap mounting with tool
> 10·cs	snap mounting by hand

for inside diameters of 25mm or more, and dependant on radial cross section (cs), seals may be snapped into closed housings.

insertion chamfer

in order to avoid damage to the rod seal during installation, the piston rod is to be chamfered and rounded as shown in the "recommended mounting space" drawing. the size of chamfer depends on the seal type and profile width.

cs (mm)	c (mm)	
	α = 15° ... 20°	α = 20° ... 30°
4	3,5	2
5	4	2,5
6	4,5	3
7,5	5	4
10	6	5
12,5	8,5	6,5
15	10	7,5
20	13	10

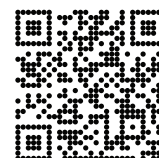

SEAL SPEC S03-P

recommended mounting space

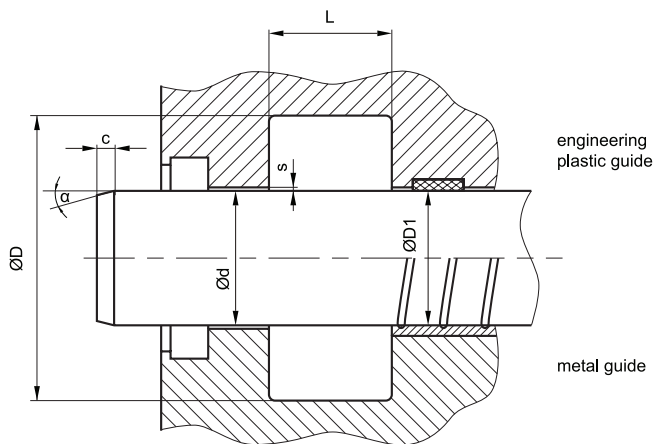

seal & housing recommendations

please note that we are able to produce those profiles to your specific need or any non standard housing. for detail measurements, please see seal-mart catalog...

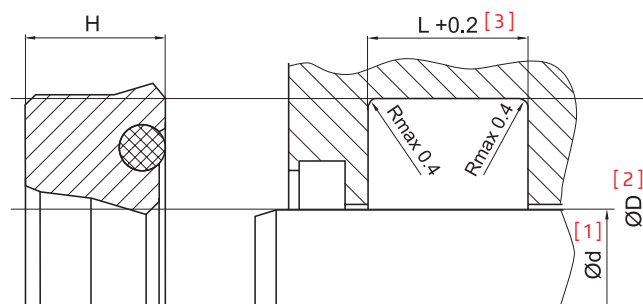

recommended guide tolerance D1

d f8 [mm]	p ≤ 100 [bar]	100 < p ≤ 200 [bar]	p > 200 [bar]
≤ 100	H10	H8	H8
> 100 ≤ 200	H10	H8	H7
> 200	H9	H8	H7

Ød [mm] [1]	ØD [mm] [2]	L [mm] [3]	cs = (ØD - Ød)/2 [mm]
5 ~ 24,9	ØD + 8	6,3	4
25 ~ 49,9	ØD + 10	8	5
50 ~ 149,9	ØD + 15	10	7,5
150 ~ 299,9	ØD + 20	14	10
300 ~ 499,9	ØD + 25	17	12,5
500 ~ 699,9	ØD + 30	25	15
700 ~ 1000	ØD + 40	32	20
> 1000	ØD + 40	32	20

fitted

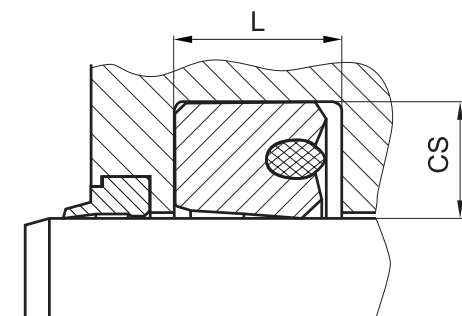

the ratio between nominal width and seal height cs/H should not drop below 1/125. therefore we recommend the following housing heights.

