

# SEAL SPEC S09-D

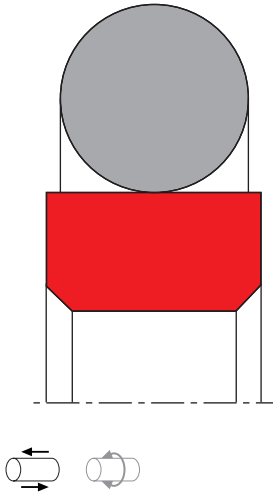

## description

o-ring activated symmetric PTFE rod seal, low friction. for extreme low or high speed, suitable for positioning functions.

- + asymmetric single acting composite rod seals, with a gliding part made of excellent wear resistant polyurethane and an elastic preload element.
- + interference fit on the outside diameter.
- + various materials are available for different purposes.
- + the generously dimensioned chamfer reduces the risk of gap extrusion.
- + good sealing effect across a wide temperature range.
- + for pressures up to 400 bar (in special cases up to 800 bar) as a seal between pressurised spaces.
- + good sealing in all pressure ranges.
- + good static and dynamic sealing.
- + suitable for short and long travel with extremely slow or quick movements.
- + no stick-slip. exact positioning due to little friction.
- + small break-away load after prolonged periods of standstill.
- + high mechanical efficiency.
- + insensitive to thermal damage caused by air in the oil.
- + radial grooves assure a fast pressure activation of the seal.

## category of profile

machined or molded/standard/trade product.

## single acting

the S09-D seal is designed for use as a rod seal.

## area of application; hydraulics

- reciprocating rods on hydraulic cylinders, small swivelling motion permissible.
- main field application is pressure intensifiers and control elements.
- for heavy-duty operating conditions, profile S09-ES is preferred.
- dimensions according to ISO 7425 part 2 are common, as well as standard types that differ slightly in the depth of the mounting space. for specific dimensions see "range of profile sizes".

## note

- the calculation program is based on mounting spaces according to ISO 7425, part 2. intermediate sizes are possible, with an o-ring for standard sizes. for deviating dimensions, use S09-ES. attention must be given to a balanced ratio between sealing part and preload element.
- there should be enough space for trailing oil.
- the recovery capacity depends on the sealing system.
- because of the fluid transport between the pressurised spaces this seal is only suitable to seal same media.

## function

S09-D profiles are composite rod seals designed to seal between two pressurised spaces; mainly for reciprocating movements. the design is based on application in standard hydraulic systems with conventional hydraulic oils. the operating parameters are as defined in the sealing data sheet and material data. requirements deviating from these parameters can be met to a certain degree by changing the geometry in the software program.

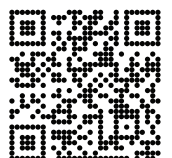

## operating parameter & material

sealing element	material energizer	back-up ring	temperature	max surface speed	max pressure <sup>1</sup>	hydrolysis	dry running	wear resistance
PTFE glass	NBR (70 shore A)	-	-30 °C ... +100 °C	10 m/s	400 bar (40 MPa)	-	++	+
PTFE bronze	NBR (70 shore A)	-	-30 °C ... +100 °C	10 m/s	400 bar (40 MPa)	-	++	+
PTFE carbon	NBR (70 shore A)	-	-30 °C ... +100 °C	10 m/s	400 bar (40 MPa)	-	++	+
PTFE glass	FKM (75 shore A)	-	-20 °C ... +200 °C	10 m/s	400 bar (40 MPa)	-	++	+
PTFE bronze	FKM (75 shore A)	-	-20 °C ... +200 °C	10 m/s	400 bar (40 MPa)	-	++	+
PTFE carbon	FKM (75 shore A)	-	-20 °C ... +200 °C	10 m/s	400 bar (40 MPa)	-	++	+
PTFE glass	EPDM <sup>2</sup> (70 shore A)	-	-50 °C ... +150 °C	10 m/s	800 bar (80 MPa) <sup>3</sup>	++	++	+
PTFE bronze	EPDM <sup>2</sup> (70 shore A)	-	-50 °C ... +150 °C	10 m/s	400 bar (40 MPa)	++	++	+
PTFE carbon	EPDM <sup>2</sup> (70 shore A)	-	-50 °C ... +150 °C	10 m/s	400 bar (40 MPa)	++	++	+
PTFE glass	MVQ (70 shore A)	-	-60 °C ... +200 °C	10 m/s	400 bar (40 MPa)	++	++	+
PTFE bronze	MVQ (70 shore A)	-	-60 °C ... +200 °C	10 m/s	400 bar (40 MPa)	++	++	+
PTFE carbon	MVQ (70 shore A)	-	-60 °C ... +200 °C	10 m/s	400 bar (40 MPa)	++	++	+
UHMWPE	MVQ (70 shore A)	-	-60 °C ... +80 °C	10 m/s	400 bar (40 MPa)	++	+	+
XPU	MVQ (70 shore A)	-	-30 °C ... +110 °C	5 m/s	600 bar (60 MPa)			

<sup>1</sup> pressure ratings are dependent on the size of the extrusion gap.

++ particularly suitable

+ suitable

o conditional suitable

- not suitable

<sup>2</sup> attention: not suitable for mineral oils!

<sup>3</sup> only in special cases (small extrusion gap, low surface speed)

the stated operation conditions represent general indications. it is recommended not to use all maximum values simultaneously. surface speed limits apply only to the presence of adequate lubrication film.

for detailed information regarding chemical resistance please refer to our "list of resistance". for decreased leakage rates elastomer materials (polyurethane or rubber) in other sealing systems are to be preferred.

note on special material:

as temperature limit and chemical resistance are determined by the preload element, the temperature range can be increased and the resistance to chemical influences improved, if a special material is used for the preload element.

## gap dimension

operating pressure	cs = (ØD - Ød)/2 mm						
	2,45	3,65	5,35	7,55	10,25	12	13,65
	safe extrusion gap (mm)						
100 bar (10 MPa)	0,27	0,33	0,38	0,43	0,50	0,55	0,60
200 bar (20 MPa)	0,19	0,25	0,28	0,33	0,37	0,43	0,45
300 bar (30 MPa)	0,17	0,20	0,22	0,25	0,30	0,34	0,38
400 bar (40 MPa)	0,16	0,18	0,19	0,21	0,25	0,28	0,30

the above data are maximum value and can't be used at the same time. e.g. the maximum operating speed depend on material type, pressure, temperature and gap value. temperature range also dependent on medium.

the table refers to a operating temperature of 80 °C. temperatures below may increase the safe extrusion gap slightly, at temperatures above 80 °C, the gap dimensions has to be reduced or a stronger profile selected. for extrusion gap sizes resulting from tolerance pair H8/f8 pressure ranges above 400 bar can be reached in special cases, influences due to thermal expansion have to be considered. we recommend to contact our technical department.

## surface quality

surface roughness	Rtmax (µm)	Ra (µm)	seal housing tolerance	
sliding surface	≤2	≤0,05-0,3	Ød	f8
bottom of groove	≤6,3	≤1,6	ØD	H10
groove face	≤15	≤3		

## tolerance recommendation

## mode of installation

Ød	type of installation
≤ 6·cs	open mounting space required
> 6·cs ..... ≤ 10·cs	snap mounting with tool
> 10·cs	snap mounting by hand

for inside diameters of 25mm or more, and dependant on radial cross section (cs), seals may be snapped into closed housings.

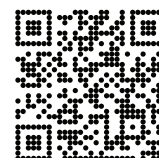

# SEAL SPEC S09-D

## insertion chamfer

in order to avoid damage to the rod seal during installation, the piston rod is to be chamfered and rounded as shown in the "recommended mounting space" drawing. the size of chamfer depends on the seal type and profile width.

cs (mm)	c (mm)	
	$\alpha = 15^\circ \dots 20^\circ$	$\alpha = 20^\circ \dots 30^\circ$
2,45	2,5	1,5
3,65	3,5	2
5,35	4,5	3
7,55	5	3,5
10,25	6	5
12	8	6
13,65	10	7

## recommended mounting space

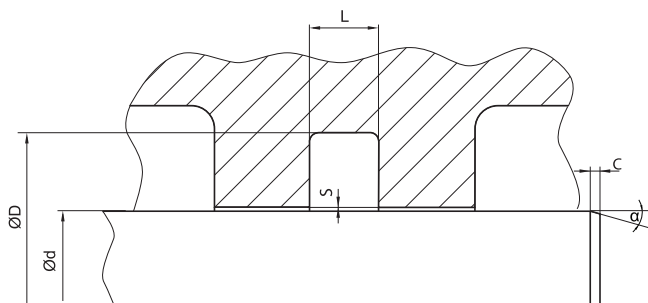

## recommended guide tolerance D1

d f8 [mm]	p ≤ 100 [bar]	100 < p ≤ 200 [bar]	p > 200 [bar]
≤ 100	H10	H8	H8
> 100 ≤ 200	H10	H8	H7
> 200	H9	H8	H7

## seal & housing recommendations

please note that we are able to produce those profiles to your specific need or any non standard housing. for detail measurements, please see seal-mart catalog...

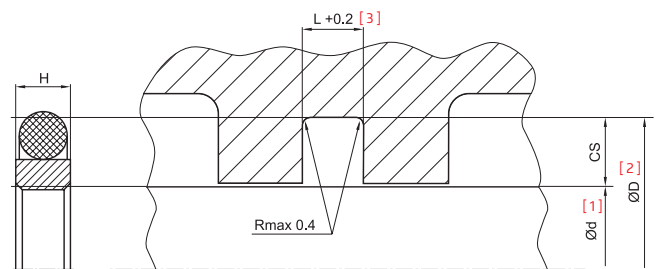

Ød [mm] [1]	ØD [mm] [2]	L [mm] [3]	cs = (ØD - Ød)/2 [mm]
5 ~ 7,9	ØD - 4,9	2,2	2,45
8 ~ 18,9	ØD - 7,3	3,2	3,75
19 ~ 37,9	ØD - 10,7	4,2	5,5
38 ~ 199,9	ØD - 15,1	6,3	7,75
200 ~ 255,9	ØD - 20,5	8,1	10,5
256 ~ 649,9	ØD - 24	8,1	12,25
650 ~ 1.000	ØD - 27,3	9,5	14
> 1000	ØD - 27,3	9,5	14

in case of large deviations of L use S09-DS.

## fitted

