

description

back-up rings have no intended sealing function. instead, as their name indicates, they are protective and supporting elements made from extrusion-resistant materials which generally have a rectangular cross section. they are installed in a groove together with an elastomeric sealing element preferably with a corresponding o-ring in static applications.

due to the tight fit of the back-up ring in the housing, they prevent extrusion of the pressurised elastomeric sealing element into the sealing gap common inactive back-up ring especially for o-ring to avoid gap extrusion. split and non split design available.

category of profile

machined or molded/standard/trade product

application

- injection moulding machines.
- machine tools.
- presses.
- excavators.
- agricultural machines.
- valves for hydraulic circuits.

advantages

- use of o-ring in high pressure applications
- use of o-ring materials with a low hardness
- compensation of radial sealing gaps
- use for internal and external sealing applications
- reciprocating and rotating movements possible
- compensation for large temperature fluctuations
- static and dynamic applications

external sealing (bore)

back-up ring types, uncut

- concave cross section
- the large contact surface protects the o-ring against deformation in case of high pulsating pressure
- dimensional stability of the o-ring improves the sealing force and increases the service life
- dynamic & static use
- reciprocating & rotating movements possible

back-up ring types, cut

- concave cross-section
- cut angle of 30° or 45°
- the large contact surface protects the o-ring against deformation in case of high pulsating pressure
- dimensional stability of the o-ring improves the sealing force and increases the service life
- static and dynamic use
- reciprocating movements possible
- preferred for installations in a closed groove where uncut back-up rings are not suitable

internal sealing (rod)

back-up ring types, uncut

- concave cross-section
- the large contact surface protects the o-ring against deformation in case of high pulsating pressure
- dimensional stability of the o-ring improves the sealing force and increases the service life
- static and dynamic use
- reciprocating movements possible

back-up ring types, cut

- concave cross-section
- cut angle of 30° or 45°
- the large contact surface protects the o-ring against deformation in case of high pulsating pressure
- dimensional stability of the o-ring improves the sealing force and increases the service life
- static and dynamic use
- reciprocating movements possible
- preferred for installations in a closed groove where uncut back-up rings are not suitable

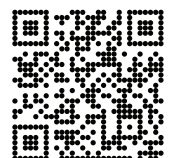

operating parameter & material

material	temperature
POM	-50 °C ... +100 °C
PA	-40 °C ... +100 °C
PTFE virgin	-200 °C ... +260 °C
PTFE glass	-200 °C ... +260 °C
PTFE bronze	-200 °C ... +260 °C
PTFE carbon	-200 °C ... +260 °C
PU	-30 °C ... +110 °C
HPU	-20 °C ... +110 °C
LTPU	-50 °C ... +110 °C
GPU	-30 °C ... +110 °C
NBR	-30 °C ... +100 °C
FKM	-20 °C ... +200 °C

POM up to ø260 mm, PA above ø260 mm

the stated operation conditions represent general indications. it is recommended not to use all maximum values simultaneously. surface speed limits apply only to the presence of adequate lubrication film.

tolerance recommendation

seal housing tolerance	
Ød	f7
ØD	H9

surface finish according to o-ring instructions

seal housing tolerance	
Ød	h9
ØD	H8

the location of the sealing surface is determinant for the functionality

design instructions

the recommendations for o-ring (see catalogue "o-ring") are generally valid for the use of back-up rings. this applies to the groove design, surface roughness, lead-in chamfers, etc.

when the pressure is applied from one side only, it is sufficient to install a back-up ring on the downstream side of the o-ring. when the seal is exposed to pressure from both sides, two back-up rings -one on each side of the o-ring have to be used.

permissible sealing gap

the use of back-up rings allows the service pressure and/or permissible sealing gap specified in our o-ring catalogue to be increased. back-up ring installation, depending on the direction of the pressure

seal & housing recommendations

please note that we are able to produce those profiles to your specific need or any non standard housing. for detail measurements, please see seal-mart catalog...

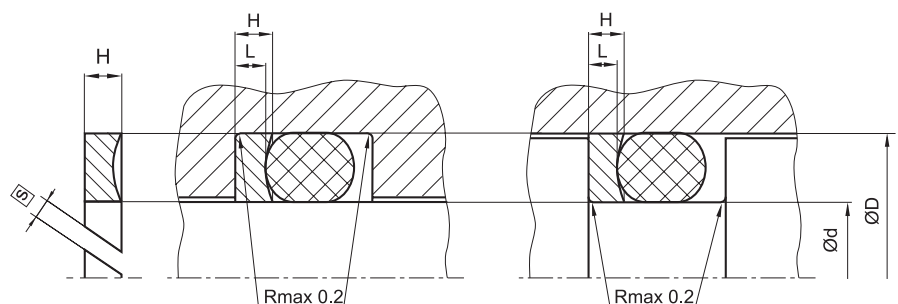

variations:
 - cutting gap width $s=0$ mm
 - endless

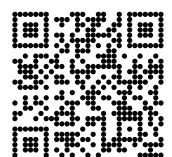

SEAL SPEC ST09



installation recommendations static & dynamic application

external sealing (bore), back-up ring types, uncut & cut, r max 0,2mm

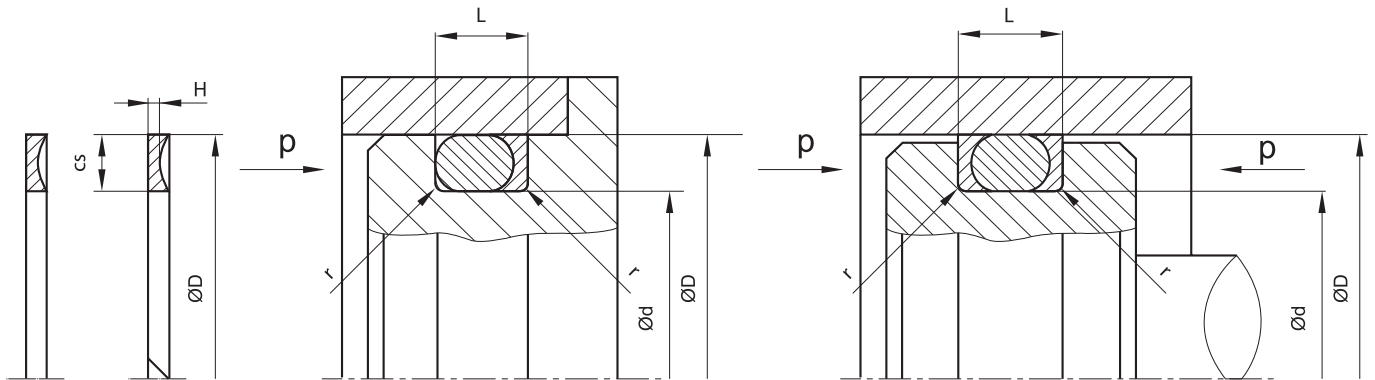

internal sealing (rod), back-up ring types, uncut & cut, r max 0,2mm

